

Introduction

► Feature

- Line pull: 2,722 kg / 6,000 lb wire rope first layer
Wire rope: 7.1 mm × 24.4 m (9/32" × 80') galvanized aircraft A7 × 19
Brake: Patented cone brake holds full load
Clutch: Turn the T-handle for rapid wire rope payout
Control: Handheld pendant switch powers the winch

► Unpacking

- Winch assembly..... 1 pc
- Detachable control box 1 pc
- Remote control..... 1 pc
- Wire rope with hook..... 1 pc
- Roller fairlead..... 1 pc
- 1.8 m (6') 6 gauge battery leads..... 1 pc

► Read this manual carefully

You should carefully read and understand this manual before operating it. Careless winch operation may result in personal injury hazards or property damage.

► Information requesting or parts ordering

Please specify the followings information:

- Winch PN
- Serial number
- Part description
- Replacement part number
- Quantity for each part

Installation

Before using the winch, make sure all electrical components have no corrosion or damaged; the environment should be clear and dry.

► Winch and roller fairlead mountings

- It is very important that the winch will be mounted on a flat and hard surface of mounting

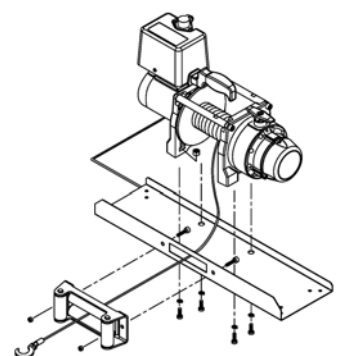

channel in order to make sure the motor, drum and gearbox housing are aligned correctly.

- Roller fairlead does not mount to winch directly.
- The wire rope shall be wound in an under-wound orientation only.
- Four (4) M10 x 1.50 pitch 8.8 grade high tensile steel bolts must be used in order to sustain the loads imposed on the winch mounting.
- Two (2) M12 x 1.75 pitch 8.8 grade high tensile steel bolts must be used for fastening the roller fairlead into the mounting channel.

► Wiring Diagram

Attach the black lead firmly to the negative (-) battery terminal and red lead to the positive (+) battery terminal. The voltage drop for the winch motor must not exceed 10% of the nominal voltage of 12/24V DC.

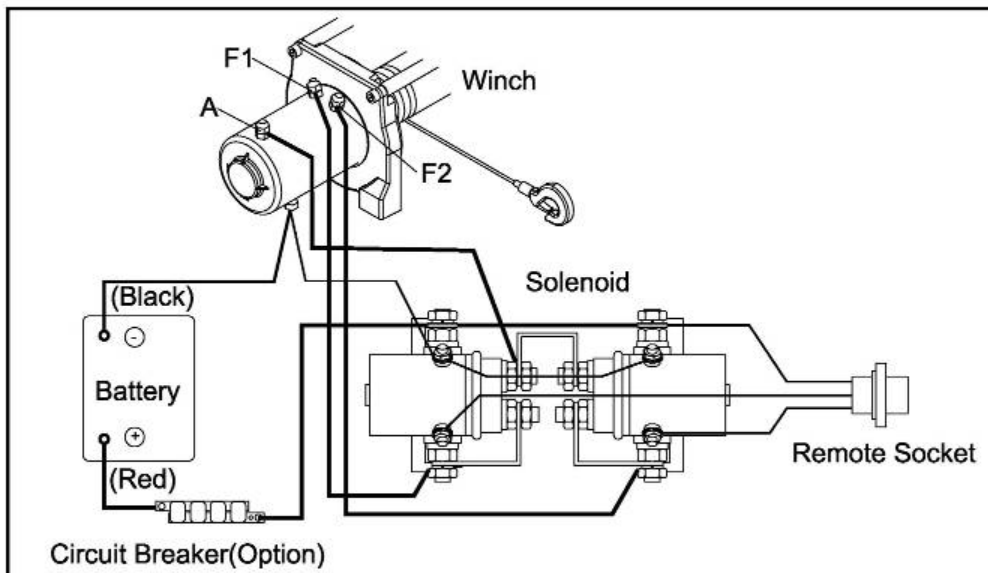

► Nut fastening for motor & contactor

1. Holding the lower nut on the stub and fastening the upper nut clockwise.
2. The torque setting for nut is 14 N-m/124 lb-in.

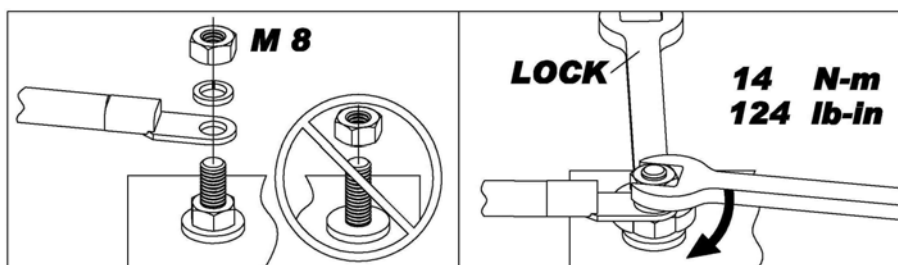

Warning

- The winch is not intended to be used in any manner for the movement or lifting of personnel.
- The rated line pull shown is based on the first layer of rope on the drum.
- The rope winding on the drum shall remain 5 wraps from the drum.

Parts List

Ver:12

Item No.	Description	Part No.	Qty
1	Motor 12V	881505	1
	Motor 24V	881506	
2	Tie bar kit	880076	2
3	Motor support rack	880077	1
4	Motor coupling	880078	1
5	Drum bushing	880006	1
6	Drum kit	880080	1
7	Drum bushing B	880081	1
8	Gearbox support rack	880082	1
9	Wire rope w/hook	880083	1
10	1 st shaft	880084	1
11	Grounding lead	880085	1
12	3 rd ring gear kit	880086	1
13	2 nd stage carrier	880087	1
14	1 st stage carrier	880088	1
15	Retaining ring	880089	1
16	1 st & 2 nd ring gear	880090	1
17	1 st pinion kit	880091	1
18	Clutch kit	880092	1
19	Gear box kit	880093	1
20	Cone brake disc kit	880094	1
21	Brake clutch base	881099	1
22	Brake cover kit	880095	1
23	Roller fairlead WA-0508	880096	1
24	Mounting hardware	880097	1
25	Remote control WA-0310	880025	1
26	Handsaver strap	880026	1
27	Detachable control box 12V	880098	1
	Detachable control box 24V	880099	
27-1	Remote socket kit	881289	1
27-2	Detachable control pack 12V	881446	1
	Detachable control pack 24V	881447	
28	Handle kit	880103	1

Winch Assembly

